



OBJECTIVE

Automate the process of cleaning the facade of glass buildings, minimize the risks of the workers and reduce maintenance costs.



METHODOLOGY

Mechanical design

- 3D design of the robot
- Calculations of the mechanism used to attach vacuum cups to the facade.
- Design and finite element analyses of a safety system to avoid a falling of the robot.

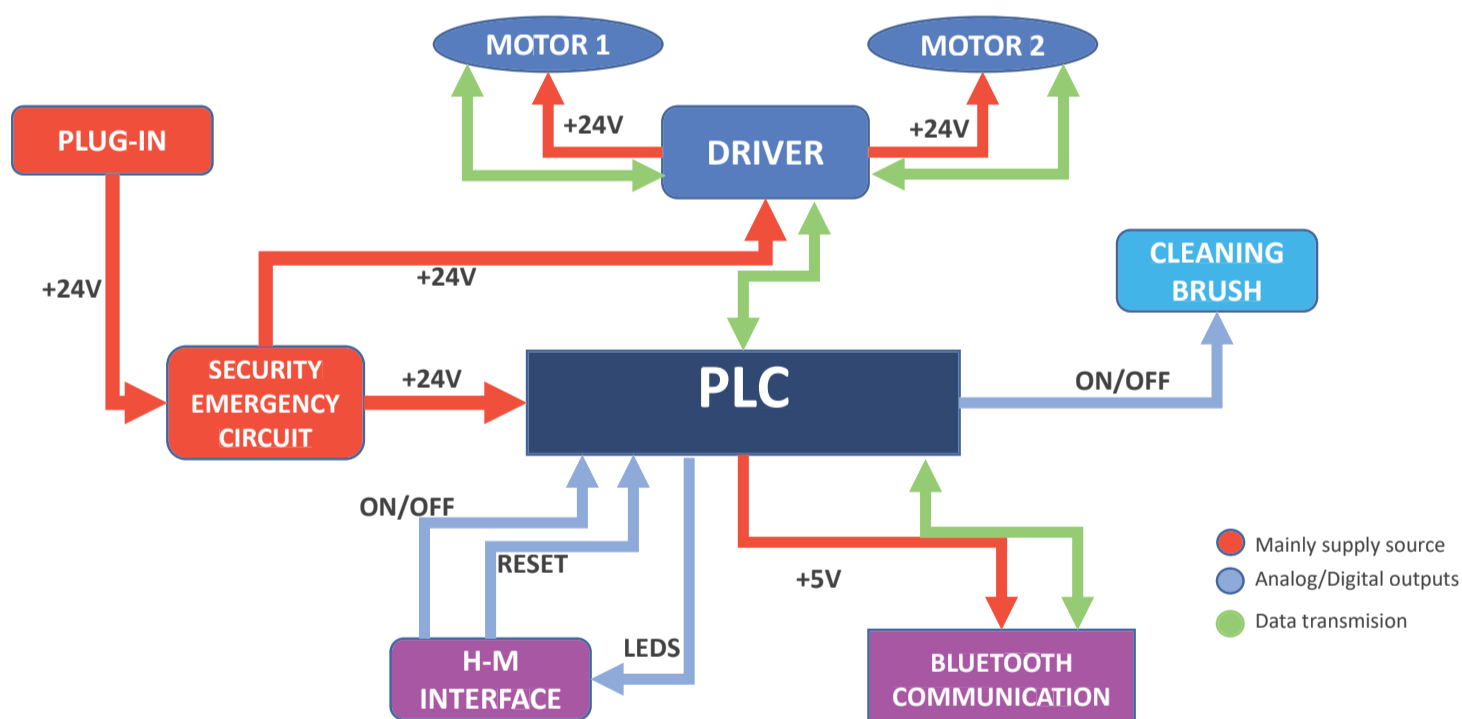
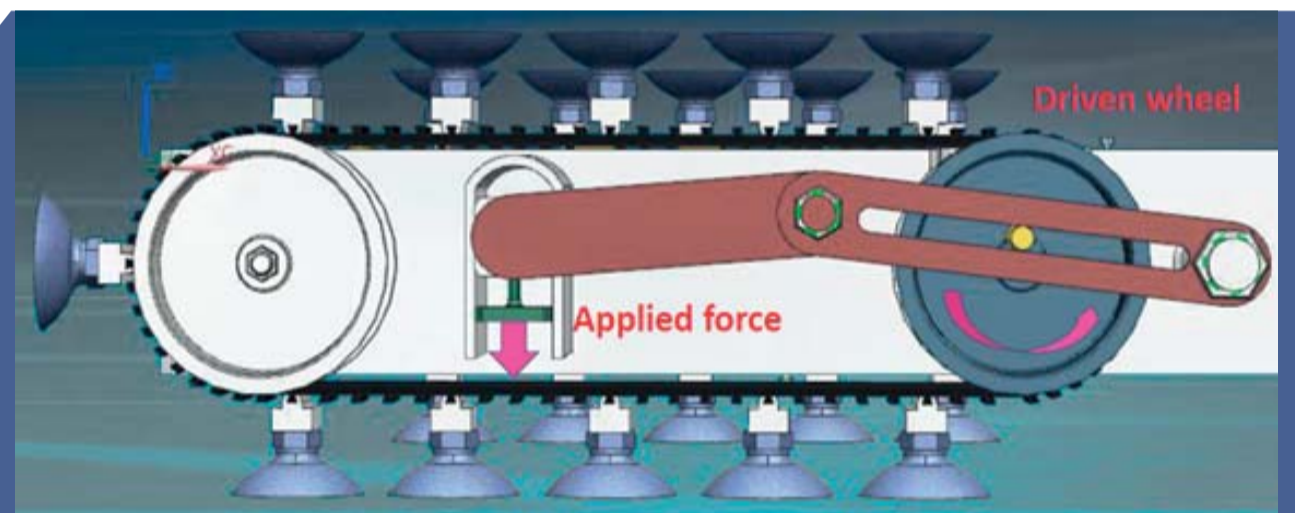

Electric design

- Electric circuit design controlled by a mini-PLC based on Arduino (Controlino).

Programming codes

- Code program for PLC to control the locomotion part.
- Design and programming of an Android app to send initial parameters of the building.

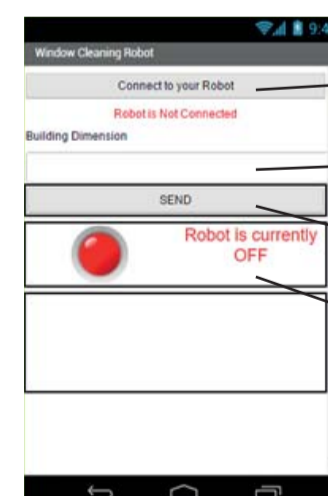

- Set up Bluetooth list to connect
- Working space dimensions
- Button to send data to the controller
- Interface to inform the status of the robot

RESULTS

- The Whitworth mechanism used was successfully to avoid any pneumatically system or other kind which would need to be controlled. However, after doing all the calculations, this mechanism should be improved to apply the force in several points instead of one in each side.
- The electrical system has been designed correctly. To improve this part, a PCB should be designed to reduce space and get a more industrial product.
- Since the android app is controlled by Bluetooth because of his simplicity, a Wifi connection would improve the range to stop the robot from the distance.